

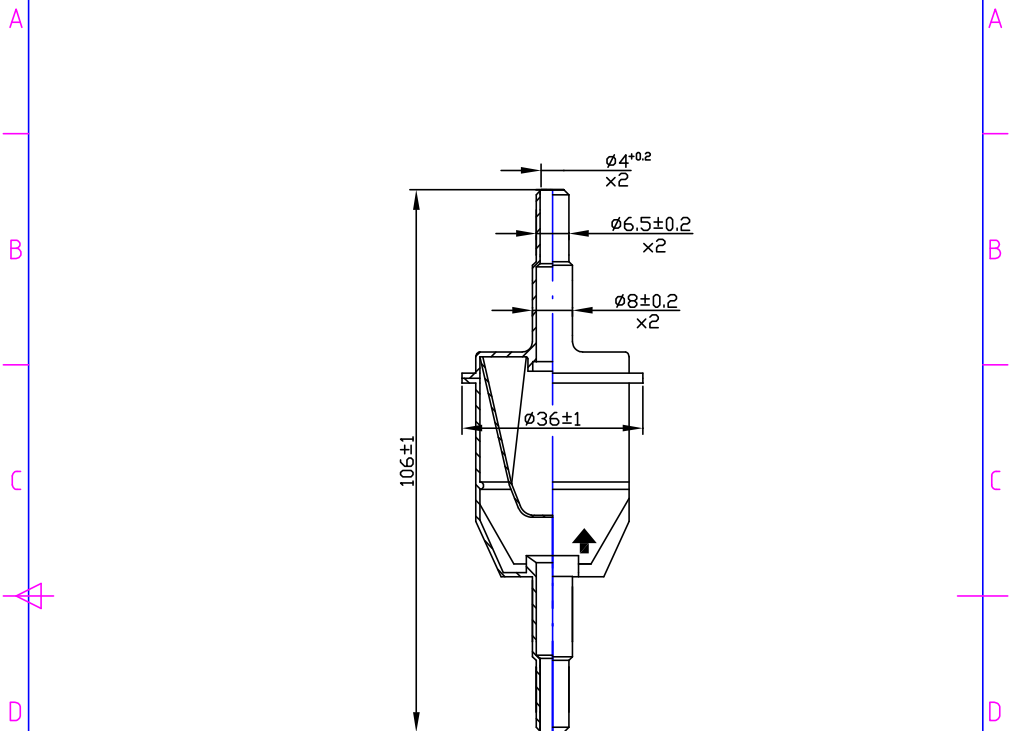

1	2	3	4
RevNo	Revision note	Date	Signature
			Checked



Test Requirements:
1. Testing pressure for leakage: 3 BAR
2. Burst Pressure: 4 BAR
3. Element Collapse Pressure: 6 BAR
4. Temp. Range: -40 °C - +100°C
5. Filtration Area : 46 ± 10% SQcm
6. Micron rating: 12 - 15 mic

All the dimensions are in mm and REF.

Itemref	Quantity	Title/Name, designation, material, dimension etc	Article No./Reference
Designed by Shvartsman	Checked by Shvartsman	Approved by - date 3/02/05	Filename GFW-31/2
		Date 3/02/05	Scale 1:1
 <b>GUR</b> filter co. ltd. Automotive Fuel Filter 12 Hanerikava Str., Industrial Zone, Holon 9890, Israel Tel. 972-3-5503615 FAX: 972-3-5503353		<b>GFW-31/2</b>	
		<b>FUEL FILTER</b>	Edition 0 Sheet 1/1